

Ford Ranger EGR Cooler replacement

HOW TO DO IT RIGHT!

Original units have been known to leak coolant either externally from around the flanged joints on either side of the cooler or internally, with coolant leaking into the engine's intake system, pulled along by the recirculated exhaust gases. Both of these failures are cause for EGR cooler replacement.

Goss has re-engineered the PX Ranger cooler and developed a new manufacturing process to produce a superior product less prone to cracking or leakage. Unfortunately, using a quality replacement part is only half the battle – installation of these units requires additional inspections and a very concise coolant-bleed procedure.

STEP 1:

Inspect the failed unit to determine the cause of the original failure

- A leak due to corrosion will require the cooling system to be flushed before installation of the new unit.
- A split core may have been triggered by over-pressurisation. Be sure to check for cylinder combustion leaks.
- A leaking coolant hose can draw air into the system, resulting in hotspots and poor flow through the cooler.
- Make sure the heater core has not been bypassed. This practice removes a critical part of the cooling system, again resulting in reduced flow through the EGR cooler.
- Check if the EGR valve itself has not been blanked off. The EGR needs to function to ensure correct and efficient cooler operation.

When installing the new cooler, replace the mounting bolts with new units and torque to manufacturer specifications using mild-strength thread-locking compound as they are prone to vibrate loose, causing the cooler to crack.

STEP 2:

Bleeding procedure

Vacuum bleeding is the only way to guarantee there are no airlocks within the system during coolant filling. This will prevent repeat failure of the cooler.

Attach the bleed adaptor to the coolant-fill point and open the air valve. After a few minutes of operation, the coolant hoses will flatten and the pressure gauge will stabilise with a negative value. Close the valve and disconnect the shop air supply.

Monitor the gauge for a few minutes for any rise in pressure. This indicates an air leak that must be rectified before continuing. If the gauge remains at negative pressure during this interval, the refill process can begin.

Keep an eye on the coolant level in the fill container – do not let the suction hose lift air or you will need to start again. When the gauge rises to zero, the system is full, with no air locks. Start the engine and allow it to warm up.

Confirm the thermostat opens by checking temperature at both top and bottom hoses. Remember to recheck for any leaks through a full temperature cycle of the cooling system.

Goss is a leading provider of genuine alternative aftermarket and original equipment supplier (OES) parts. With more than 75 years of experience developing and sourcing some of the world's leading OES and aftermarket parts, offering workshops a genuine alternative.



THE GENUINE ALTERNATIVE

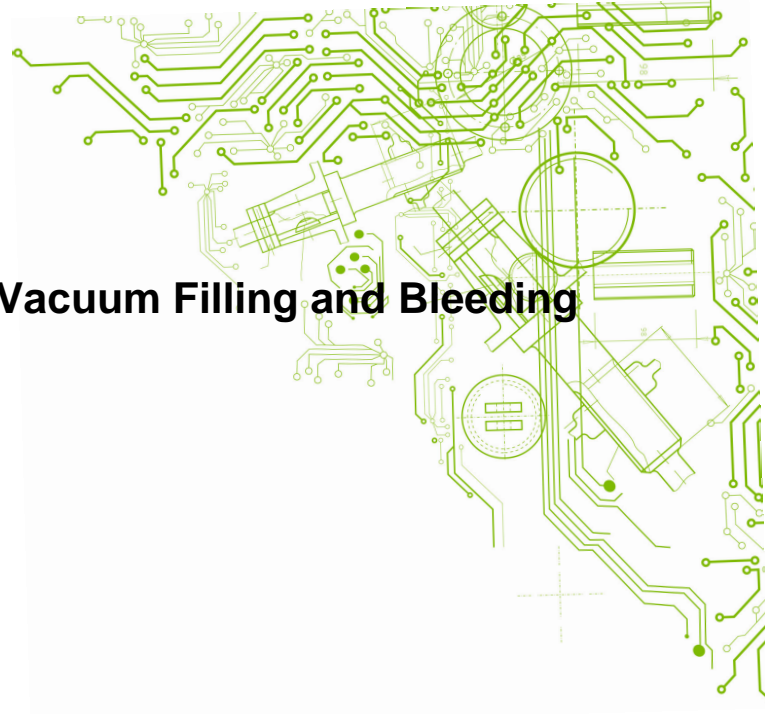

Engine Cooling System Draining, Vacuum Filling and Bleeding

Special Tools / General Equipment

Fluid Container

Cooling System Vacuum Tester and Refiller

Materials

Name	Specification
Antifreeze	WSS-M97B44-D2



Draining

WARNING: When releasing the cooling system pressure, cover the coolant expansion tank cap with a thick cloth.

NOTE: Always follow the manufacturer's instructions when handling the equipment.



Release the cooling system pressure by slowly turning the coolant expansion tank cap between 2 and 3 turns.

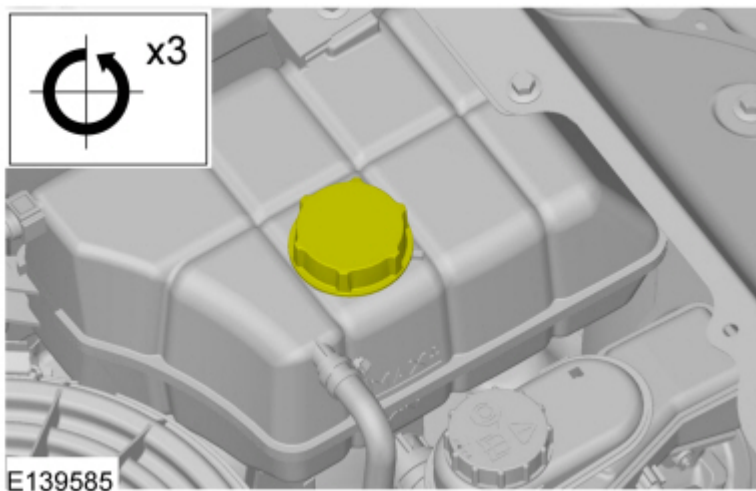



WARNING: Be prepared to collect escaping fluid.

Connect a hose to drain the coolant. Open the radiator drain valve and drain the engine coolant in a suitable, clean container.

Use the General Equipment: Fluid Container

Loosen: 4 turn(s)

Evacuating and Filling

NOTICE: The cooling system is filled with Motorcraft® Orange Antifreeze/Coolant. Do not mix coolant types. Mixing coolant types degrades the corrosion protection of the coolant. Failure to follow these instructions may damage the engine or cooling system.

NOTICE: Engine coolant provides boil protection, corrosion protection, freeze protection, and cooling efficiency to the engine and cooling components. In order to obtain these protections, maintain the engine coolant at the correct concentration and fluid level in the degas bottle.

NOTE: Add Motorcraft® Orange Antifreeze/Coolant or equivalent.

NOTE: Do not add or mix with any other type of engine coolant. Mixing coolants may degrade the coolant's corrosion protection.

NOTE: Do not add alcohol, methanol, or brine, or any engine coolants mixed with alcohol or methanol antifreeze. These can cause engine damage from overheating or freezing.

NOTE: Ford Motor Company does NOT recommend the use of recycled engine coolant in vehicles originally equipped with Motorcraft® Orange Antifreeze/Coolant since a Ford-approved recycling process is not yet available.

- If the cooling system was completely drained, fill the fluid container with the full cooling system fill capacity plus 0.5L of additional coolant.
Material: Antifreeze (WSS-M97B44-D2)
- If the cooling system was partially drained, fill the fluid container with the removed and spilled amount of coolant plus 1.0L of additional coolant. When in doubt always use the full cooling system fill capacity plus 0.5L of additional coolant.

Material: Antifreeze (WSS-M97B44-D2)

Close the radiator drain plug.

Remove the coolant expansion tank cap.

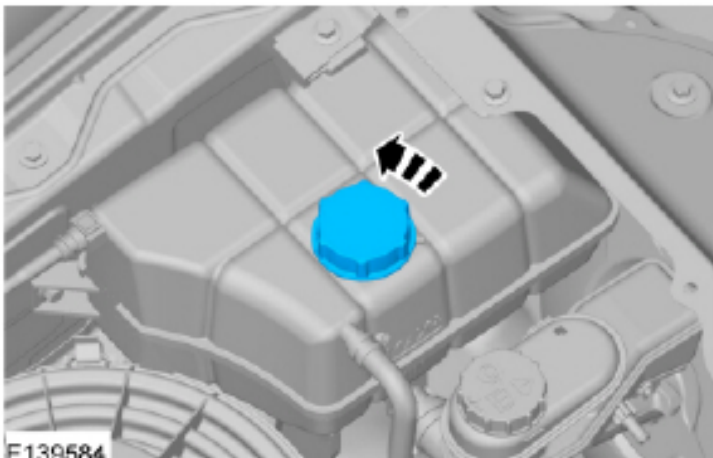

1. Close the valve, install the coolant hose and place it into the fluid container. Use the General Equipment: Cooling System Vacuum Tester and Refiller
2. Close the valve and connect the compressed air hose.

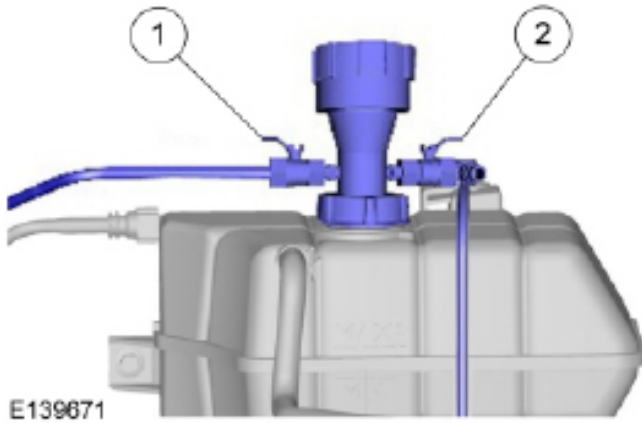

1. Use the General Equipment: Cooling System Vacuum Tester and Refiller
2. Open the valve until the specified vacuum is achieved.

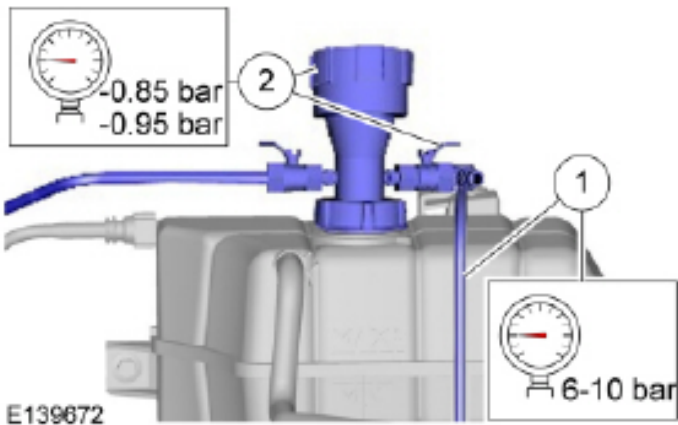

- Open the valve until the coolant reservoir fluid level is at the MAX mark.
- Use the General Equipment: Cooling System Vacuum Tester and Refiller
- If no coolant is visible in the coolant expansion tank, add 2.0L of coolant to the fluid container and repeat the evacuating and filling procedure.
- *Material:* Antifreeze (WSS-M97B44-D2)

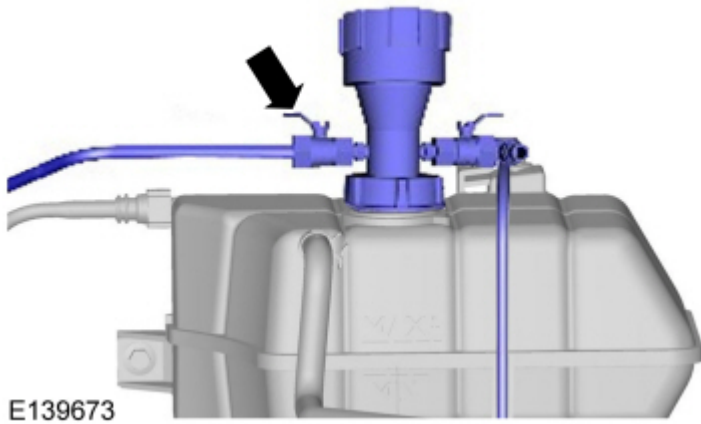

Install the pressure relief cap until it contacts the hard stop.

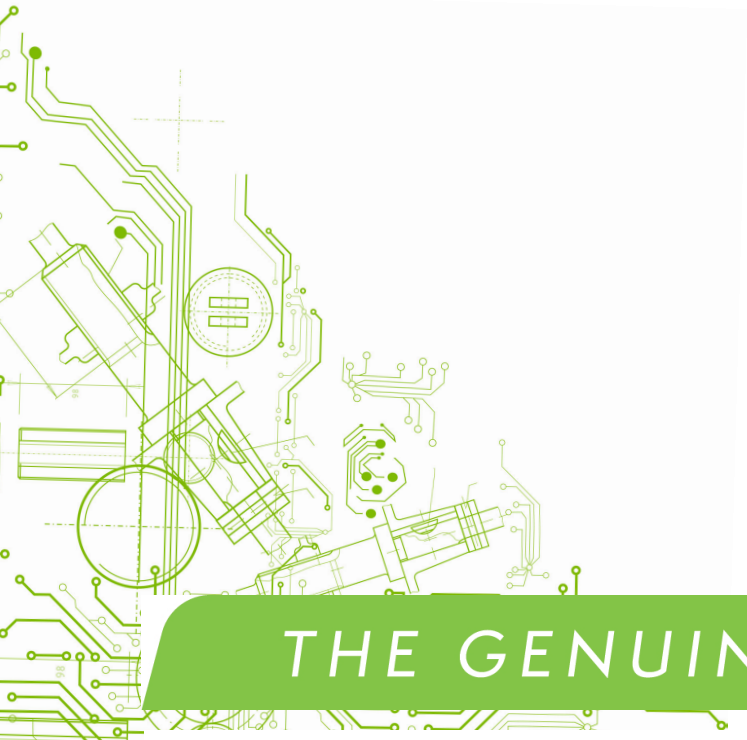
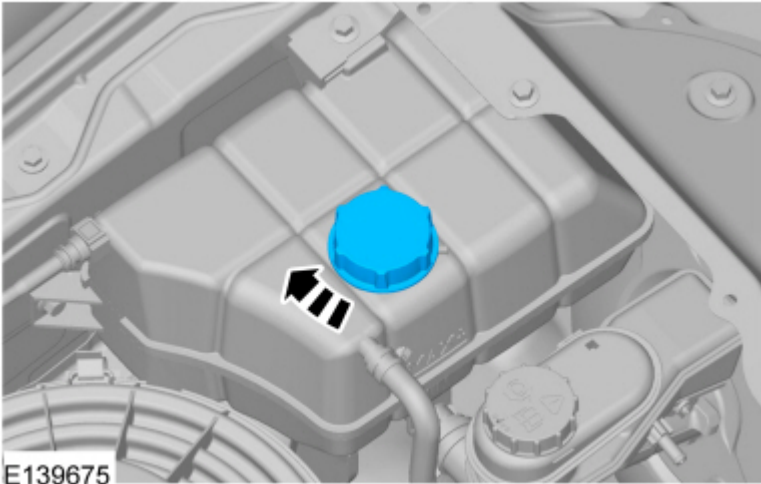

THE GENUINE ALTERNATIVE